

# DATA SHEET

## PRODUCT DESCRIPTION

The mobile unit on wheels LINEA MONOLIFT is designed to accommodate equipment and instruments in a functional way, guaranteeing practicality and stability during use.

## TECHNICAL FEATURES

ITEMS	DESCRIPTION
SHELF	Dimensions: 400 x 360 mm
COLUMNS	Material: Extruded aluminium
BASE	Tubular shape, equipped with ABS shock-absorbing caps
BASKET	Material: Wire mesh
WHEELS	Diameter: 80 mm. Equipped with two front brakes to ensure stability and safety during use, while facilitating a comfortable movement of the unit.
OPTIONS	Cable holder arm; Plastic baskets; Conditional shelf; probe holders;
VERNICIATURA	Epoxy in thermal tunnel at 200° C



# ASSEMBLY INSTRUCTIONS

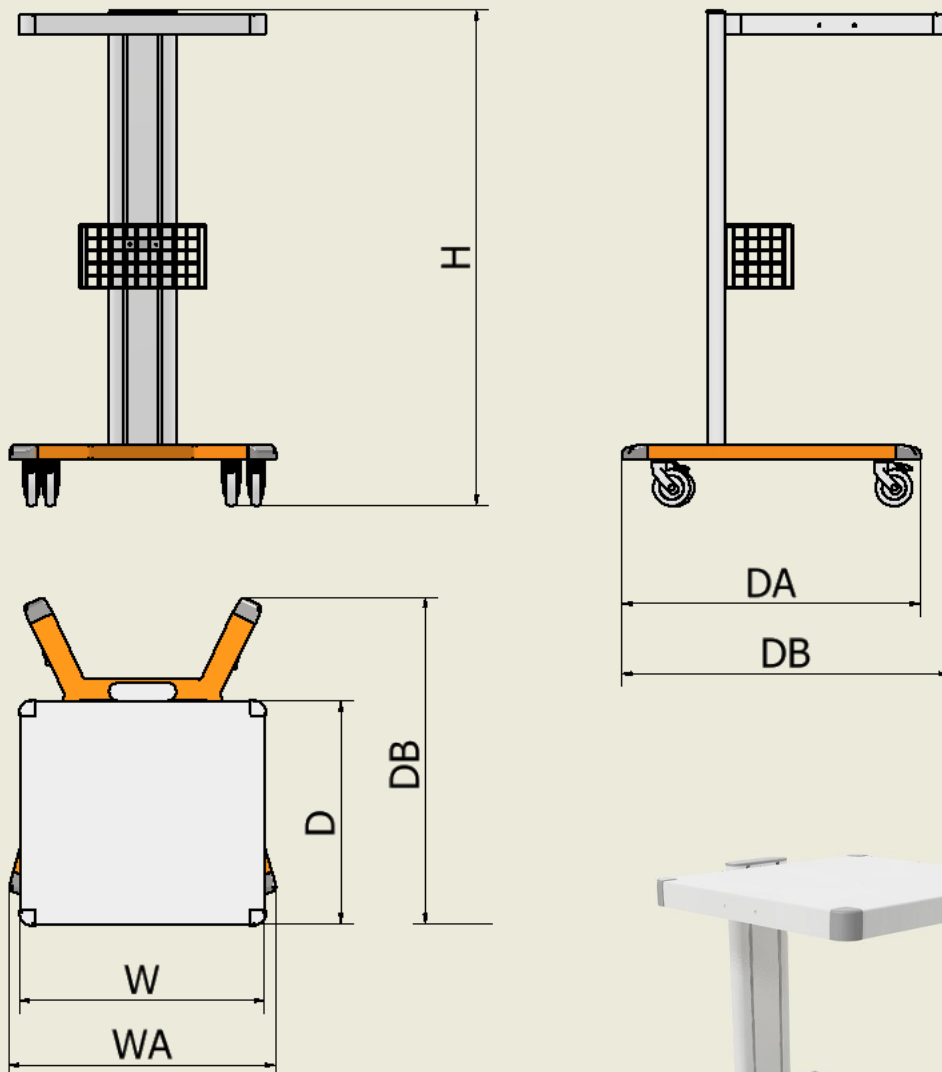

Structure	
Max Total Flow	25 kg
Column	Aluminum
Wheels (mm Ø)	82



# ASSEMBLY INSTRUCTIONS

Structure dimensions			
H	DA	DB	WA
mm	mm	mm	mm
82	450	500	450

Shelves	
W	D
mm	mm
360	400

## CUSTOM SOLUTIONS

450



**Scan To Visit Our Website**

To visit our websites, open your phone's camera app and scan the QR code below,  
[www.kartmedsolutions.com](http://www.kartmedsolutions.com)

